



We Are Focusing on Pumps
for More Than 20 Years.

CONTENTS

- 01 Company Profile
- 02 Honour
- 03 Base
- 05 History
- 07 Equipment
- 11 Testing Process
- 13 Product Introduction
- 42 Service

01 | COMPANY PROFILE

Shanghai Kaiquan Pump (Group) Co. Ltd. is a large professional pump enterprise, specialised in designing, production and sales of high quality pumps, water supply systems and pump control systems. It is the leading pump manufacturing group in China. The strength of more than 5000 staff members, comprising of over 80% of college diploma holders, over 750 engineers, doctors, makes it the best choice for the talent. The group owns an asset of 500 million USD, 7 enterprises and 5 industrial parks in Shanghai, Zhejiang, Hebei, Liaoning and Anhui, covering a total area of almost 7,000,000 square meters and manufacturing facilities of over 350,000 square meters.

Shanghai Kaiquan was awarded the following honorable titles: Shanghai Quality Golden Prize, the fourth place in Top 100 Shanghai PVT Enterprise, Shanghai Top 100 Technical Enterprise, Grade AAA China Quality Credit, Grade AAA National Contract Credit, Excellent Enterprise in Quality, Creditability and Services, China's Most Competitive Commodity Trademark, and Advanced Unit of National Enterprise Cultural Construction. In 2014, Shanghai Kaiquan was selected as Top 500 in mechanical industry for three consecutive years, leading the first place in the pump industry nationwide.

Shanghai Kaiquan ranks the first in amount of sales in the national pump industry for 16 consecutive years, and the group's sales volume came 600 million USD in 2017, almost double volume of the arch rival which led the second place. With its 300 engineers, Shanghai Kaiquan has combined the services with technology. With the help of ERP and CRM systems, it provides professional solutions to its customers in least time. Moreover, it has established a national service network with 32 sales branch companies and 361 agencies. In addition, it carries out the "Blue Fleet Services" and the 4-hour

reaction mechanism, responding to the demands of customers at any time. Shanghai Kaiquan's first priority is always to produce the competitive and reliable products and to satisfy customers.

Shanghai Kaiquan is committed to manufacture high end pumps for the specialised fields like nuclear power plants, large scale fire fighting, petrochemical, military projects and desalination plants to contribute to thriving Chinese market as well as the international market. Shanghai Kaiquan intends to step into world's Top 10 pump manufacturer in the near future.





Management System Certificate



Environment system certificate



ISO 14001 Environment Management System Certificate



EC-attestation Certificate of LVD



Design and Manufacturing License of Civil Nuclear Safety Facilities



03 | BASE



> Hefei Industrial Park

The former Hefei Kaiquan Motor & Electrical Pump Co., Ltd. is Hefei Sanyi Motor & Electrical Pump Co., Ltd., which was the professional manufacturer of motors and submersible electric pumps designated by the original national machinery industry. In 2008, Shanghai Kaiquan Pump (Group) Co., Ltd. purchased the original Hefei Sanyi Motor & Electrical Pump Limited Liability Company and established Shanghai Kaiquan Motor & Electrical Pump Co., Ltd., which has become a new privately-operated high tech enterprise.

Currently, Hefei Kaiquan Motor & Electrical Pump Co., Ltd., covering an area of 270,000 square meters and a building area of 230,000 square meters for production, has put the total investment of one billion yuan for its construction. It was put into use with the completion of the first-phase extension project in 2011. Currently, it has more than 800 employees, of whom 78 are engineering technicians including 16 senior engineers and three experts enjoying the State Council Special Allowance. There are advanced testing, inspection and designing facilities of motors and pumps. Its hydraulic experimental station is the biggest one in Asia.

Hefei Kaiquan Motor & Electrical Pump Co., Ltd. is the major submerged pump production base of the Group. Major products are submersible sewage pump, axial/mixed flow pumps, mine submerged pumps and their high and low-pressure motors. The products are widely used in the fields such as municipal administration, water conservancy and mines, and are well appreciated by their purchasers at home and abroad.



> Shenyang Industrial Park

Shenyang Kaiquan Petrochemical Pump Co., Ltd. is a wholly-owned subsidiary built by Shanghai Kaiquan Pump Group, located in the state-level Shenyang Economic and Technological Development Zone in the North-east Old Industrial Base and covering an area of nearly 34,000 square meters and the workshop area of 12,000 square meters. The Company has 130 staff members now, of whom are 3 senior engineers, 20 engineers and 152 specialized persons, where there are 200 sets of machines such as NC machine tools, large-sized machine tools, high-speed balancing machines, nondestructive testing automatic welding devices. At present, it is an annual production capacity of 7000 pump sets.

The Company currently manufactures nine series and 200 varieties of corrosion preventive industrial pumps, which meet the requirements of API610, ANSI B73.1M and ISO2858. The product parameters are: flow 2,000m³/h, pumping head 600m, temperature -55~+450°C, NPSH 0.5m, and inlet pressure 1.5Mpa. Its products are widely used in chemical, petrochemical, medicine, steel & iron, coking, coal, environment protection, starch, automobile, non-ferrous metals and paper industries.

The Company's perfect production equipment and testing facilities, excellent administrative staff, strict management and organization based on procedures and documents of ISO9001 international systems in production, all well improve product quality.



➤ Shijiazhuang Industrial Park

Shijiazhuang Kaiquan Trash Pump Co., Ltd. was established in 2005 with the investment of 20 million USD, covering an area of 47,000 square meters and a building area of around 22,000 square meters. At present, the Company has 150 experts, senior & intermediate engineering technicians and skilled workers. There are the world advanced resin production line and the continuous sand mixers. Its casts adopt phenolic sand molding. Its two 2-ton and two 1-ton medium frequency furnaces can cast the 8-ton single alloy pieces. In addition, it has more than 300 sets of equipments such as 4m and 2.5m vertical lathes, universal borer, radial drilling machine and numerically controlled lathe.

At present, the Company is the trash pump manufacturing base of the Group, and its products cover 5 series and 160 types, meeting demands of the transmission of materials containing solid particles in mine, metallurgy, coal production, power plant desulfuration, river dredging, alumina and coal chemical industry.



➤ Zhejiang Industrial Park

Kaiquan Group Zhejiang Industrial Park is located in Donggou Industrial Park on the bank of Ou River in Wenzhou. Its original is the Oubei Pump Factory founded in September 1988, and was renamed as Zhejiang Kaiquan Pump Manufacturing Co., Ltd. in May 1994. In July 2002, the Company was relocated to the new industrial park, and renamed as Kaiquan Group Co., Ltd, with a registered capital of 102 million yuan. It covers an area of 50,000 square meters and a building area of 23,678 square meters in Zhejiang Industrial Park. Now it has 290 staff members and 213 sets of processing and testing equipments with an annual production capacity of more than 100,000 sets and yearly output value of 35 million USD.

The Company manufactures dozens of types and around 100 series of products such as single stage pumps, multistage pumps, submersible sewage pumps and chemical pumps. The Company has passed ISO9001:2000 quality management system certification. It aims to satisfy customers.

05 | HISTORY

1990

Oubei Pump Factory, the predecessor of Shanghai Kaiquan Pump (Group) Co., Ltd was founded. In the same year, Oubei Pump Factory was renamed as " Zhejiang Kaiquan Pump Manufacturing Co., LTD" .

1996

Developed the state-level new product-KQL vertical single-stage centrifugal pump.

1998

Shanghai Kaiquan Huangdu Industrial Park was formally put into production.

1995

Shanghai Kaiquan Water Supply Engineering Co., Ltd was founded. It focused on its development in Shanghai in the direct-sales model, which is a pioneer in Chinese pump industry.

2001

Zhejiang Kaiquan Industrial Park with total investment of 18,500,000 USD was put into production.

1999

Shanghai Kaiquan Pump (Group) Co., Ltd was founded with ISO9000 certificate.

2003

Monthly order has exceeded 16,700,000 USD, which made a solid foundation to become the top 20 enterprise in world pump industry.

2003

Kaiquan Group was completed the merger of Shanghai Tangfeng Electrical Apparatus Factory.

2001

Kaiquan Group was completed the combination and reformation of the existing marketing channel and begun large size direct marketing.



1995



1996



1998



2000



2001



2003

2005

Kaiquan Group was completed combination and reformation of existing production system and set up 10 professional branch factories, which means the professional development in the pump and mining industries.

2007

The thesis "Research and popularization of the theory and key technology of submersible pump" was awarded the second prize on improvement of national science and technology.

2010

Kaiquan Group was invested 25,000,000 USD to build high-precision closed test bed and big pump test bed.

2008

Kaiquan Group purchased the Hefei Sanyi Factory and built a production base with a covering area of 270,000 square meters there.

2007

Kaiquan Group gained the ISO14001 Environment Quality Certification

2011

Kaiquan Group was committed to the development of the stage II, III pump for nuclear power plant and the main water supply pump, circulation pump, condensate pump, vacuum pump, magnetic pump, etc used in the normal nuclear island.



2005



2006



2010



2011



2012



2013

07 | EQUIPMENT



> Large Testing Bed

The testing bed is mainly used for full-speed and full-capacity tests for main circulation pump, condensate pump, and large size double suction pump used for 1000MW nuclear and thermal power plants. It has the following parameters: the pool capacity is 13,000m³; the height of overhead crane above testing bed is 24m; the single-hook craned capacity is 200 tons; the voltage is 10KV; and the maximum testing pump flow is 25m³/s.



> Thermal Shock Testing Bed

It had successfully made the thermal shock test for nuclear high-voltage safety injection pump (stage II) at its completion, meets requirements of thermal shock test with the appraisal by the experts at home, and can be used to do the thermal shock test, trash test and operation test for nuclear pumps (stage II and III) in 1000MW nuclear power.



> High-precision Closed Testing Bed

The testing bed is mainly used for the best-hydraulic model pump test, with multifunction, four quadrants and normal position indicating at the comprehensive accuracy of 0.25%, which can verify the complete performance parameters of model pump accurately.



> High-temperature & High Pressure Testing Bed

The testing bed can be used to do the full-speed, high-temperature and high-pressure tests for primary supply pumps used in 1000MW thermal and nuclear power plants. It can test performance parameters by imitating the practical operation conditions to verify the performance and reliable indexes.



> Large Size Pump Performance Testing Center

The testing center is mainly used for the type and full performance tests of the large-size pump products, with the following parameters: the pool capacity is 2,000m³; the maximum testing pump caliber is 1,200mm; voltages are 380V, 6KV and 10KV; the maximum testing pump flow 9m³/s; and the maximum testing motor power is 2,200KW.



> Testing Bed in Hefei Factory

The testing bed is mainly used to test large size high-voltage submersible pump by the cofferdam way with following parameters: the maximum testing pump capacity is 20m³/s; voltages are 380V, 600V, 3KV, 6KV and 10KV; and the maximum testing motor power is 6,000KW.



> Open Full Automatic Testing Bed

It is mainly used for the type and full performance tests, with the following parameters: the pool capacity is 800m³; and the maximum testing pump caliber is 600mm; the voltage is 380V; the maximum testing pump capacity is 4,000m³/h; the maximum testing motor power is 315KW.



> Vacuum Pump Testing Bed

Our company has built two vacuum pump testing beds with a maximum tested gas capacity of 60,000m³/h, maximum tested motor power of 1250KW and vacuum rage of 0.0-0.1MPa. It can be used to test performance of vacuum pump, electric vacuum equipments, chemical vacuum equipments and vacuum water drawing equipments.

09 | EQUIPMENT



➤ WFT13 boring and milling horizontal machining center with five-axle four-linkage control



➤ AC46TM-4000 heavy-duty high precision vertical lathe-milling machining center



➤ Floor Boring and Milling machining center with nine-axle five-linkage control



➤ Big gantry boring and milling machining center



➤ KVL-1600ATC boring and milling machining center



➤ Heat treatment workshop



➤ TRT314HS high-speed machining center with six-axle five-linkage control



➤ ProfiMill 4000/100-T Gantry boring and milling machining center with six-axle five-linkage control



➤ 5-meter NC vertical lathe



➤ 5-axes, 5-linkage machining center



➤ 8-meter large-size NC vertical lathe



➤ 10-meter large-size NC horizontal lathe

11 | TESTING PROCESS

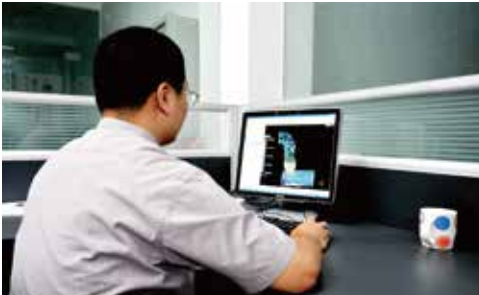

▶ Quality Requirements

Our company has acquired the ISO9001 certificate and has applied quality control program in the factory to realize the strict control on product quality. In our company, the professional technician provides drawings and technical specifications; the craft man provides the technical procedures and industrial equipment requirements; and the quality control department provides standards on production, purchase, and test.



▶ Examination on Suppliers

Quality control department organizes related technicians, craft man, and purchase staff to make a technical and quality evaluation on different suppliers of mold, motor, casting parts, and standard components. The suppliers who have passed the evaluation are recognized as qualified supplier of Kaiquan.

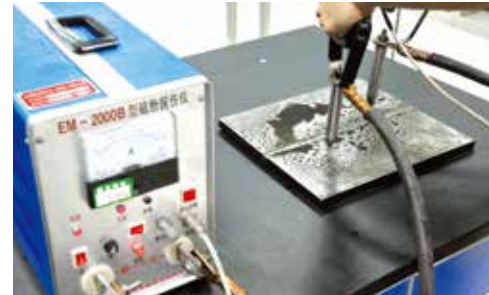

▶ Examination on Suppliers

The common casting parts, spare part and standard parts are inspected in the factory. For example, every 2 ton casting parts should prepare 3 Siamese test bar for intensity test. Only the qualified one can be used, or the whole parcel should be returned. And the key components are inspected on-site, as: sending the quality tester to do the flaw inspection for every shaft in the suppliers' factory. Only the qualified one are ordered.



▶ Intensity Inspection

After heat treatment, quality control department will make configuration inspection and intensity inspection on the spare parts. Intensity test adopts tensile test and torsion test to inspect its tensile and torsion ability.



▶ Metallographic Analysis after Heat Treatment

After intensity test, the qualified metal spare parts as shaft, stainless casting parts, standard components should have the second metallographic analysis to see if the metallographic structure is qualified after the heat treatment. Only the qualified one can be machined, or it will be deserted.



▶ Machining of spare parts

The manufacturing workshop will process the spare part strictly according to the technological procedures by using of special facilities, the guidance of R&D department and technology department, the supervision and inspection of quality control department. The qualified parts can be into the next assembling procedure.

Since 1999, our company has passed a series of quality management system, environment management system, and occupational health & safety management system certificates. The certification organization is Audit Center of Shanghai Quality System. In 1999, we got ISO9001:1994 certificate. In 2002, we got ISO9001:2000; in 2007, we got ISO14001:2004 environment management certificate; In Jan. 2010, we got GB/T28001-2001 occupation health safety management system.

In June, 2010, Audit Center of Shanghai Quality System had a on-site evaluation of the management system in our workshops. And our corporation passed the yearly inspection of QMC, EMC, and OHSMC successfully.



Composition Analysis of Raw Materials

Material research laboratory is in charge of the materials needed in our company. The physical and chemical laboratory proceed physical and chemical analysis on the raw materials of casting parts, semi-finished product. There are many special analyzing machines that can make chemical composition analysis on metallic and non-metallic materials as cast iron, carbon steel, stainless steel, rubber, etc. All the materials are selectively inspected after being sent into the factory. Only the qualified material is sent to be machining.



Metallographic Analysis of Raw Materials

Material research laboratory makes metallographic analysis chart for different metal material. The physics and chemistry laboratory makes the metallographic analysis on the metal parts as shaft, stainless steel casting parts, and standard components to test if the quality of nonmetal impurity has exceeded the standard and test if the metallographic structure can meet the standard.



Rough Machining and Heat Treatment

Make rough machining and inspection for spare parts that have passed metallographic and composition analysis. Then heat treatment workshop makes heat treatment on those spare parts. The technical procedures and specifications of heat treatment are made by material research laboratory and specialist will be in charge of the heat treatment.



Inspection of spare parts

According to specific technologic process, quality control department will process the first and shift inspection during the machining process and take the selective examination after the parts have been machined. And the small batch product all should be inspected. Only the qualified parts can be sent to the assembly shop.



Product Assembly

According to specific technologic process, assembly shop will assemble the spare parts by using special industrial equipments R&D and crafts sector will give the guidance while the quality control department will be supervised and tested after assembled. Only the qualified one can be sent to the test center to have the performance test.



Performance Test

Test center is in charge of the performance test of products according to testing specifications and customers' special requirements. Test results of pump hydraulic performance, motor performance, noise and vibration will be sent to the quality control department. Only the qualified one can be consigned to the customers.

According to the regulation on "Regulation Rules on Civil Nuclear Safety Facilities" (HAF601), our group has submitted the design and manufacture certificate for the nuclear pumps used in the second and third circulation circuits, and has been accepted by National Nuclear Security Bureau.

At present, we have had the ability to design, manufacture and test all kinds of nuclear pumps according to the American ASEME standard and French " Pressurized Water Reactor Nuclear Construction System" standard.

To ensure the safety management of nuclear pump system, our group has built a series of quality management regulation rules on the design and manufacture of nuclear pumps. In our company, especially in the nuclear pump department, every employe has in mind of "strictly stick to the regulations on nuclear safety, avoid any kind of excuses in nuclear." During the manufacturing process, we believe in the nuclear culture of "Safety first, Quality first, Pursue excellence" and make sure the effective implementation of the safety measures.

13 | PRODUCT INTRODUCTION

Nuclear Power Station

Nuclear power, one of the cleanest energy resources, is the main direction of power energy development. Our company has accumulated many R&D and application experience by continuous development. We have successfully developed many nuclear pump products, such as stage high-pressure safety injection pump, containment spray pump, nuclear island sump pump, etc. Now we are committed to development of the stage 2 and 3 pumps for nuclear power plant and primary water-supply pump, circulation pump, condensate pump, vacuum pump, magnetic pump, etc., which are used in the normal nuclear island.



PRODUCT INTRODUCTION | 14

Technical data



Containment Spray Pump
Low-pressure Safety Injection Pump

Speed:	1480r/min
Capacity:	850m ³ /h
Head:	92.5m
Liquid Temperature:	150 C
Max.Pressure:	2.5MPa



Nuclear Secondary High-pressure Safety Injection Pump

Speed:	2960r/min
Capacity:	0 ~ 120m ³ /h
Head:	420 ~ 1060m
Liquid Temperature:	135 C
Max.Pressure:	13.5MPa



Pump for Important Plant

Speed:	980r/min
Capacity:	3300m ³ /h
Head:	40m
Liquid Temperature:	50 C



1,000,000KW Nuclear Power Nuclear 3-level Fire Pump

Speed:	2975r/min
Capacity:	353m ³ /h
Head:	127.5m
Liquid Temperature:	50 C
Max.Pressure:	1.0MPa

15 | PRODUCT INTRODUCTION

Technical data



Condensate Pumps for 1,000,000KW Nuclear Power and Thermal Power

Speed:	1480r/min
Capacity:	1958m ³ /h
Head:	245m
Liquid Temperature:	50 C
Max.Pressure:	4MPa



Primary Feed Pump

Speed:	5215r/min
Capacity:	3372.8m ³ /h
Head:	705m
Liquid Temperature:	180 C
Max.Pressure:	130MPa



Primary Feed Pump Set

Speed:	5215r/min
Capacity:	3372.8m ³ /h
Head:	848m
Liquid Temperature:	180.9 C



AP1000/CPR1000 Circulating Water Pump

Speed:	197r/min
Capacity:	43200 ~ 72000m ³ /h
Head:	12 ~ 35m
Liquid Temperature:	20 C
Max.Pressure:	1MPa

PRODUCT INTRODUCTION I 16

Technical data



Equipment Cooling Water Pump

Speed:	1480r/min
Capacity:	3160m ³ /h
Head:	70m
Liquid Temperature:	100 C
Max.Pressure:	2.0MPa



Residual Heat Removal Pump

Speed:	1490r/min
Capacity:	610m ³ /h
Head:	77m
Liquid Temperature:	190 C
Ambient Temperature:	-10 ~ 40 C
Max.Pressure:	6.21MPa



AP1000 Make-up Pump

Speed:	2985r/min
Capacity:	0 ~ 42.1m ³ /h
Head:	1776 ~ 1925m
Liquid Temperature:	93.3 C



AP1000 Nuclear 3-level Residual Heat Removal Pump

Speed:	1490r/min
Capacity:	364m ³ /h
Head:	110m
Liquid Temperature:	215.6 C
Max.Pressure:	6.21MPa

17 | PRODUCT INTRODUCTION

Petrochemical Industry

The pump plays an important role in the injecting water to oil field in oil extraction, long-distance oil transferring, and petrochemical refining equipment. The pump is the mostly used one of petrochemical production facilities, which can transfer different kinds of mediums such as raw oil, readymade oil, chemical raw material, intermediate products, and end product to the other place. In the oil refining facilities, fluid delivery is mainly available by pump.

250 types and 9 series of industrial pumps made by Shenyang Petrochemical Pump Factory are up to GB standard, API610, ANSI, ISO standards, etc. The temperature for delivering medium ranges from -45 to +450 and the maximum working pressure is 9MPa. It can be used in different highly-corrosive conditions, and widely applied for processing and transport of natural gas, oil refining, chemical and fiber industries.



PRODUCT INTRODUCTION | 18

Technical data



KQWR-G Hot Water Pump

Speed:	1450, 2900r/min
Capacity:	5 ~ 800m ³ /h
Head:	6.8 ~ 240m
Liquid Temperature:	≤ 230 C
Max.Pressure:	4MPa



KSY Pipeline Oil Transfer Pump

Speed:	990, 1480 and 2960r/min
Capacity:	68 ~ 3975m ³ /h
Head:	10 ~ 230m
Liquid Temperature:	-10 C ~ 80 C
Ambient Temperature:	≤ 40 C
Max.Pressure:	≤ 2.5MPa



AY Double Suction Oil Pump

Speed:	2950r/min
Capacity:	2.5 ~ 600m ³ /h
Head:	30 ~ 200m
Liquid Temperature:	-45 C ~ 420 C

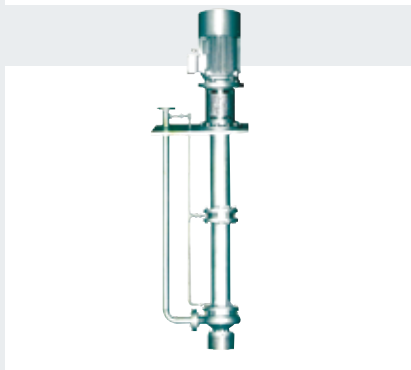

KQYH Series Under - liquid Chemical Pump

Speed:	2950r/min and 1475r/min
Capacity:	4 ~ 350m ³ /h
Head:	4 ~ 76m
Liquid Temperature:	-20 C ~ 80 C
Max.Pressure:	1.6MPa

19 | PRODUCT INTRODUCTION

Technical data



KZA Petrochemical Process Pump

Speed:	2950r/min and 1475r/min
Capacity:	0.5 ~ 3000m ³ /h
Head:	4 ~ 230m
Liquid Temperature:	-45 °C ~ 180 °C
Max.Pressure:	2.5MPa



KZE Petrochemical Process Pump

Speed:	2950r/min and 1475r/min
Capacity:	0.5 ~ 3000m ³ /h
Head:	4 ~ 230m
Liquid Temperature:	-45 °C ~ 400 °C
Max.Pressure:	4 ~ 5MPa



KZAO Standard Chemical Process Pump

Speed:	2950r/min and 1475r/min
Capacity:	2 ~ 1600m ³ /h
Head:	2 ~ 140m
Liquid Temperature:	-20 °C ~ 150 °C
Max.Pressure:	2.5MPa



AY Multi - stage Oil Pump

Speed:	2950r/min
Capacity:	2.5 ~ 600m ³ /h
Head:	30 ~ 670m
Liquid Temperature:	-20 ~ 200 °C

Coal - fired Power Plant and Biological Power Plant

Pump is a primary auxiliary component, which plays a vital role in coal-fired and biological power industries. Our company can produce all kinds of single stage pump, double suction pump, sewage pump, long-axle pump that are widely used in coal-fired and biological power generation with efficient and dependable operation. Nowadays we are committed in the products of boiler water feeding pump, circulation pump, condensate pump and vacuum pump that can be used in coal-fired and biological power generation industry.



21 | PRODUCT INTRODUCTION

Technical data



KVAH Water-ring vacuum pump units

Speed:	490 ~ 1450r/min
Capacity:	500 ~ 5000m ³ /h
Min. suction pressure:	33hpa
Air Temperature:	≤80 C



NW Series Low-pressure Drain Pump

Speed:	2950r/min and 1480r/min
Capacity:	36 ~ 450m ³ /h
Head:	55 ~ 310m
Liquid Temperature:	≤ 135 C (Saturated stem water)



KQSN series double suction pump

Speed:	298 ~ 2960r/min
Capacity:	68 ~ 30000m ³ /h
Head:	7 ~ 306m
Liquid Temperature:	< 80 C (~ 120 C)
Ambient Temperature:	≤ 40 C
Max.Pressure:	1MPa or 1.6MPa (Special configuration can reach 1.6MPa or 2.5MPa)



KCZ Standard Chemical Process Pump

Speed:	2900r/min and 1450r/min
Capacity:	1.5 ~ 2000m ³ /h
Head:	4 ~ 200m
Liquid Temperature:	-30 C ~ 150 C
Max.Pressure:	2.5MPa

PRODUCT INTRODUCTION | 22

Technical data



WQ Series Submersible Sewage Pump

Speed:	370 ~ 2940r/min
Capacity:	8 ~ 8980m ³ /h
Head:	6 ~ 84m
Liquid Temperature:	≤ 40 °C



XBD-DL series fire pump

Speed:	2950r/min and 1480r/min
Capacity:	18 ~ 270m ³ /h
Liquid Temperature:	≤ 80 °C (Clean water)
Max.Pressure:	0.3 ~ 2.5MPa



XBD-L series fire pump

Speed:	980r/min, 2960r/min and 1480r/min
Capacity:	2.5 ~ 200m ³ /h
Liquid Temperature:	≤ 80 °C (Clean water)
Max.Pressure:	0.3 ~ 1.3MPa



LC Long-axle Pump

Speed:	2950, 1475, 980, 735r/min
Capacity:	60 ~ 5100m ³ /h
Head:	13 ~ 120m
Liquid Temperature:	≤ 80 °C
Max.Pressure:	1.4MPa

23 | PRODUCT INTRODUCTION

Construction and heating

Kaiquan has gained customers' trust by advanced technology, dependable quality and excellent service. Up till 2009, the market occupation rate of our pumps on construction and heating market has been 35%. Different pump and water supply equipment of our company has been widely used in the hotels, business buildings, residential houses, heating supply, refrigeration and air-conditioning in subway and airport projects with high efficient and energy-saving characteristics.



PRODUCT INTRODUCTION | 24

Technical data



KQDP/KQDQ stainless steel multi-stage pump

Speed:	2,900r/min
Capacity:	0.8 ~ 130m ³ /h
Head:	16 ~ 263m
Liquid Temperature:	-20 C ~ 105 C
Max.Pressure:	Inlet pressure + pump maximum pressure ≤ 2.5MPa



WQ/S series chopper sewage pump

Speed:	2950, 1450r/min
Capacity:	10 ~ 320m ³ /h
Head:	4 ~ 38m
The Maximum Size of the Debris:	32 ~ 65mm



WQ/D series small size sewage pump

Speed:	2960 and 1450r/min
Capacity:	10 ~ 120m ³ /h
Head:	4 ~ 28m
Liquid Temperature:	≤ 40 C



KQL series single stage centrifugal pump

Speed:	2960 ~ 1480r/min
Capacity:	1.8 ~ 1400m ³ /h
Head:	≤ 127m
Liquid Temperature:	-10 C ~ 80 C
Ambient Temperature:	≤ 40 C
Max.Pressure:	Caliber no more than 125: 1.6MPa Caliber between 150 and 200: 1.2MPa Caliber more than 250: 1MPa

25 | PRODUCT INTRODUCTION

Technical data



KQSN series double suction pump

Speed:	298 ~ 2960r/min
Capacity:	68 ~ 30000m ³ /h
Head:	7 ~ 306m
Liquid Temperature:	< 80 °C (~ 120 °C)
Ambient Temperature:	≤ 40 °C
Max.Pressure:	1MPa or 1.6MPa (Special configuration can reach 1.6MPa or 2.5MPa)



KQSU series double suction pump

Speed:	990, 1480r/min
Capacity:	20 ~ 2000m ³ /h
Head:	20 ~ 100m
Liquid Temperature:	0 °C ~ 80 °C
Max.Pressure:	Inlet pressure + maximum pressure ≤ 1.6MPa special requirements can reach 2MPa



KQF double-model water supply system without pressure

Capacity:	8 ~ 180m ³ /h
Water Supply Pressure:	30 ~ 160mH ₂ O



WFY controllable compensated pipe-network add-pressure water supply system

Capacity:	5 ~ 200m ³ /h
Water Supply Pressure:	20 ~ 160mH ₂ O

Fire-fighting pump and related equipmentsire control system

XB D fire-fighting pump and related equipments can totally meet the national standard about fire pump on GB6425-2006. All our fire pumps have passed the inspection of National Fire-fighting Equipments Quality Inspection Center. With a widely variety of structure, excellent performance and reliable operation, XBD series products are applicable to meet the fire-fighting requirements of various buildings of different heights and pipeline arrangement. We have successfully provided large quantity of normal fire pumps and related products for subway, supermarket, hotel, airport, residential house and other building projects.



27 | PRODUCT INTRODUCTION

Technical data



XBD-DN series multi-stage fire-fighting pump

Speed:	2960r/min
Capacity:	4.5 ~ 50L/S
Liquid Temperature:	≤ 80 °C
Max.Pressure:	0.3 ~ 2.5MPa



XBD-DX series multi-stage fire-fighting pump

Speed:	1480, 2950r/min
Capacity:	1 ~ 20L/S
10 Times Outlet Pressure:	0.3 ~ 2.3MPa
Liquid Temperature:	≤ 80 °C
Max.Pressure:	0.3 ~ 2.5MPa



XBD series Long-axle fire-fighting pump units

Speed:	2950, 1475r/min
Capacity:	10 ~ 200L/S
Head:	0.3 ~ 1.22MPa
Liquid Temperature:	≤ 80 °C (Water or similar liquid)
Ambient Temperature:	≤ 40 °C



XBC series diesel fire pump units

Speed:	990, 1480, 2960r/min
Capacity:	10 ~ 800L/S
Ambient Temperature:	5 °C ~ 40 °C
Max.Pressure:	0.2 ~ 2.2MPa

PRODUCT INTRODUCTION I 28

Technical data



XBD series double suction fire-fighting pump units

Speed:	1480, 2960r/min
Capacity:	68 ~ 3975m ³ /h
Head:	6 ~ 230m
Ambient Temperature:	5℃ ~ 40℃

29 | PRODUCT INTRODUCTION

Water supply, draining and water conservancy

For the projects of urban water supply system, daily life water supply facilities, and large size water transferring, the best products and solutions can be provided with the single stage pump, multi-stage pump, double suction pump and automatic water supply equipment manufactured by Kaiquan corporation. The largest caliber of double suction pump is 1.4m, power 3000KW. Our axial/mixed flow pump, and submersible sewage pump also have been widely used in municipal water draining project, large-size irrigation project, flood control and drainage project, dock industry, irrigation projects, groundwater transferring project, and waste treatment project. For axial flow pump, the maximum caliber is 2.8m, power is 2,200KW.



PRODUCT INTRODUCTION | 30

Technical data



H type vertical mixed flow pump

Speed:	245 ~ 1480r/min
Capacity:	0.27 ~ 16.7m ³ /s
Head:	5.7 ~ 60m
Liquid Temperature:	40 °C



ZL/HL series vertical axial/mixed flow pump

Speed:	300 ~ 1450r/min
Capacity:	0.2 ~ 12m ³ /s
Head:	2 ~ 30m



ZQ/HQ submersible axial/mixed flow pump

Speed:	176.5 ~ 1450r/min
Capacity:	101 ~ 28000L/S
Head:	2.5 ~ 22m

31 | PRODUCT INTRODUCTION

Collection and Treatment of waste water

Our submersible sewage pump, submersible axial flow pump, mixer, and control systems are mainly used in the collection, discharge, and treatment of the sanitary and industrial waste water. The market occupation rate has been over 10%. Maximum caliber of submersible pump is 800mm, with 315kw power; Maximum caliber of submersible axial flow pump is 1.6m, with 800kw power, 10kv voltage. We have successfully provided sewage pump, submersible pump, mixer for over ten waste treatment factories with daily capacity of 200,000+ ton, and provided pump and control systems for dozens of large size civil rainwater pump stations.



PRODUCT INTRODUCTION | 32

Technical data



WQ/C series small size sewage pump

Speed:	2960, 1450r/min
Capacity:	10 ~ 280m ³ /h
Head:	4 ~ 36m
Liquid Temperature:	≤ 40 C



WL series vertical sewage pump(7.5KW less than)

Speed:	2960, 1450r/min
Capacity:	10 ~ 300m ³ /h
Head:	4 ~ 36m
Liquid Temperature:	≤ 80 C
Ambient Temperature:	≤ 40 C



WJA submersible agitator

Speed:	Mixed flow agitator speed 360 ~ 1450rpm push tyoe agitator speed 36 ~ 115rpm
Liquid Temperature:	≤ 40 C



WQ/S series chopper sewage pump

Speed:	2950, 1450, 980r/min
Capacity:	10 ~ 320m ³ /h
Head:	4 ~ 38m
The Maximum Size of the Debris:	32 ~ 65mm

33 | PRODUCT INTRODUCTION

Technical data



ZQ/HQ series submersible axial/mixed flow pump

Speed:	176.5~1450r/min
Capacity:	101 ~ 28000L/S
Head:	2.5 ~ 22m



WQ series submersible sewage pump

Speed:	370 ~ 2940r/min
Capacity:	8 ~ 8980m ³ /h
Head:	6 ~ 84m
Liquid Temperature:	≤ 40 °C



WJ series agitator

Speed:	36~1480 r/min
Propeller diameter:	210~730mm
Liquid Temperature:	≤ 40 °C
Submersible depth :	≤ 10m



YW series under-liquid sewage pump

Speed:	2960 ,1480,960 r/min
Capacity:	8 ~ 1,000m ³ /h
Head:	≤ 60m
Liquid Temperature:	≤ 60 °C

PRODUCT INTRODUCTION | 34

Technical data



WQ/D series small size sewage pump

Speed:	2960 and 1450r/min
Capacity:	10 ~ 120m ³ /h
Head:	4 ~ 28m
Liquid Temperature:	≤ 40 °C

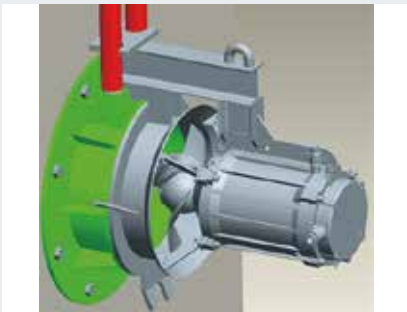

WH sludge recirculation machine

Speed:	29~980r/min
Axial force :	130~6000N
Impeller diameter :	260~2500m
Liquid Temperature:	≤40 °C

35 | PRODUCT INTRODUCTION

Metallurgy, steel plant, coal industry and mine industry

In the whole-line processes from excavation to transferring, even treatment for the industrial application as mining, steel ,metallurgical and coal, such products as MD multistage pump, KQSN double suction pump, KZJ slurry pump, YQ submersible multi-stage pump, LC long-axle pump etc. and their services can be provided by Kaiquan corporation. With the unique technology and reliable quality on special material and seal configuration, our products can be applicable to meet complex working condition of high-wearing, high temperature and explosive proof. We have successfully provide many high quality products for many famous mining and steel enterprises in China, as Shenhua Coal Factory, Rizhao Steel Factory, Jinan Steel Factory, Ma' anshan Steel Factory, and Chinese Aluminum Industry etc.

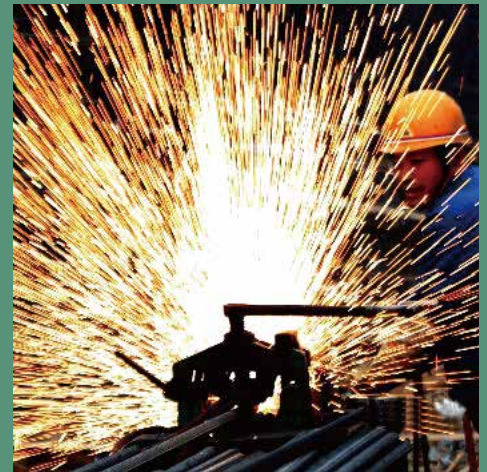

PRODUCT INTRODUCTION | 36

Technical data



YW under-liquid sewage pump

Speed:	2960, 1480, 960r/min
Capacity:	8 ~ 1,000m ³ /h
Head:	≤ 60m
Liquid Temperature:	≤ 60 °C



KWFB self-priming sewage pump

Speed:	1480, 2960r/min
Capacity:	5.6 ~ 1600m ³ /h
Head:	10~125m
Liquid Temperature:	≤ 50 °C
Ambient Temperature:	+ 40 °C



Water-ring vacuum pump units

Speed:	970~2840r/min
Capacity:	6~500m ³ /h
Min. suction pressure:	33hPa



MD multi-stage pump (for mine)

Speed:	1480, 2960r/min
Capacity:	3.75~1200m ³ /h
Head:	50~1550m
Liquid Temperature:	≤ 80 °C

37 | PRODUCT INTRODUCTION

Technical data



KQSN series double suction pump

Speed:	298~2960r/min
Capacity:	68~30000m ³ /h
Head:	7 ~ 306m
Liquid Temperature:	< 80 C (~ 120 C)
Ambient Temperature:	≤ 40 C
Max.Pressure:	1MPa or 1.6MPa (Special configuration can reach 1.6MPa or 2.5MPa)



LC long-axe pump

Speed:	2950,1475,980,735r/min
Capacity:	60 ~ 5100m ³ /h
Head:	13 ~ 120m
Liquid Temperature:	≤ 80 C
Max.Pressure:	1.4MPa



KQWR-G high-temperature hot water pump

Speed:	2900r/min
Capacity:	5 ~ 800m ³ /h
Head:	6.8 ~ 240m
Liquid Temperature:	≤ 230 C
Max.Pressure:	4MPa



WQ series submersible sewage pump

Speed:	370 ~ 2940r/min
Capacity:	8 ~ 8980m ³ /h
Head:	6 ~ 84m
Liquid Temperature:	≤ 40 C

PRODUCT INTRODUCTION | 38

Technical data



KZJ series slurry pump

Speed:	590~1480r/min
Capacity:	20~2300m ³ /h
Head:	10~110m



AH R/HH/M series slurry pump

Speed:	590~2900r/min
Capacity:	12~5400m ³ /h
Head:	6~118 m
Liquid Temperature:	80℃ (~110℃)
Ambient Temperature:	+ 40℃
Max.Pressure:	1.6MPa

39 | PRODUCT INTRODUCTION

Paper making, pharmaceutical industry, food and light industry

Our fresh water pump, sewage pump and vacuum pump are widely used in paper making, pharmaceutical, food and light industries. We have provided many high quality products that are widely used in such processes as vacuum distillation, fluid degasification, air-compressing, food/medicine process and pouring, equipment supply, waste collection and treatment, etc.



PRODUCT INTRODUCTION | 40

Technical data



2BEX water-ring vacuum pump

Speed:	210~1750r/min
Capacity:	150~27000m ³ /h
Pressure:	33~1013hPa
Air Temperature:	0 C ~ 80 C



2BVX water-ring vacuum pump

Speed:	970~2890r/min
Capacity:	27~500m ³ /h
Pressure:	33~1013hPa
Liquid Temperature:	-10 C ~ 40 C



KMC magnetic pump

Speed:	1450, 2900r/min
Capacity:	6~120m ³ /h
Head:	15~40m
Liquid Temperature:	-20~100 C



KQH/KQWH series single - stage vertical / horizontal chemical pump

Speed:	1480, 2960r/min
Capacity:	2.2~480m ³ /h
Head:	2.8~129m
Liquid Temperature:	-10 C ~ 80 C
Ambient Temperature:	+ 40 C
Max.Pressure:	1.6MPa

41 | PRODUCT INTRODUCTION

Technical data



KQDP/KQDQ series multi-stage pump

Speed:	2,900r/min
Capacity:	0.8 ~ 130m ³ /h
Head:	16 ~ 263m
Liquid Temperature:	-20~ 105 ℃
Max.Pressure:	Inlet pressure + pump maximum pressure ≤ 2.5MPa



WQ/S series chopper sewage pump

Speed:	2950, 1450r/min
Capacity:	10 ~ 320m ³ /h
Head:	4 ~ 38m
The Maximum Size of the Debris:	32 ~ 65mm



KQSN series double suction pump

Speed:	298 ~ 2960r/min
Capacity:	68 ~ 30000m ³ /h
Head:	7 ~ 306m
Liquid Temperature:	< 80 (~ 120 ℃)
Ambient Temperature:	≤ 40 ℃
Max.Pressure:	1MPa or 1.6MPa (Special configuration can reach 1.6MPa or 2.5MPa)



KZJ series slurry pump

Speed:	590~1480r/min
Capacity:	20~2300m ³ /h
Head:	10~110m

Outstanding Service System



Before-sale Service

We have very professional technical support team who are committed in providing the best suitable and economic solution plan for the customers to fulfill their requirements.

Mid-sales Service

We have professional service team to provide installation, debugging, inspection service, as well as product training for our customers.



After-sale Service

We have very a professional technical support team which is committed to providing the best suitable and economic solution for customers to fulfill their requirements.





www.kaiquangroup.com



SHANGHAI KAIQUAN PUMP (GROUP) CO., LTD.

Add: No.4255 Caoan Road, Shanghai Post Code: 201804 Service Center: +86-21-6956 6288
Oversea Department: +86-21-5651 4775 E-mail: Trading@kaiquan.com.cn